

R-1

7 RACERS
7 CRASHES
1932

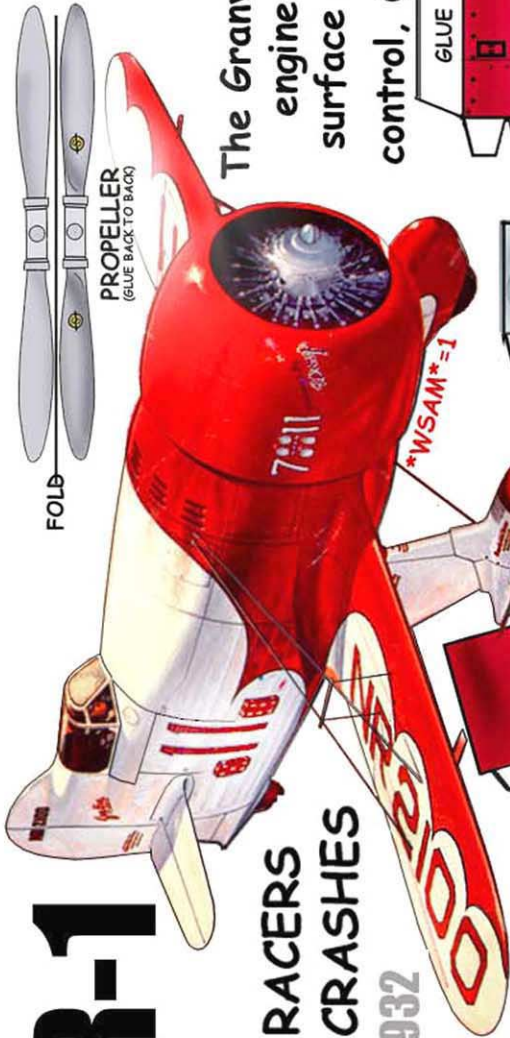

GEE BEE

The Granvilles had simply streamlined a Wasp Sr. engine & added just enough wing and control surface area to keep it airborne, barely under control, and moving at nearly 300 MPH!

550 HP P&W WASP JR ENGINE

GLUE 'ENGINE PLATE' HERE

COWLING (GLUE TOGETHER)

ENGINE PLATE

MAKE LITTLE CUTS IN THE LEADING EDGE OF THE COWLING RING AND WORK THE EDGE INTO AN INWARD CONTOUR

VERY OPTIONAL ENGINE PARTS (SEE INSTRUCTIONS)

GLUE

TUCK

CENTER SECTION

REAR FUSELAGE (ROLL & GLUE CAREFULLY)

ROLL AND GLUE TO FRONT OF CENTER SECTION

CUT OUT FOR WING AFTER BUILDING FUSELAGE

T.W.

NR2100

DAB GLUE ON TABS ONLY

PROPELLER (GLUE BACK TO BACK)

FOLD

***WSAM *1**

SHEET ONE OF TWO

MORE ON THE GEE BEE AT: WWW.FIDDLERSGREEN.NET

GEE BEE

SHEET TWO OF TWO

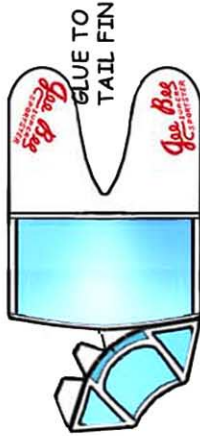

GLUE TO
TAIL FIN

CANOPY (ROLL OVER PENCIL)

BE SURE TO CHECK OUT ALL THE OTHER MODELS
IN THIS 1930S RACING PLANES COLLECTION

HORIZONTAL
STABILIZER

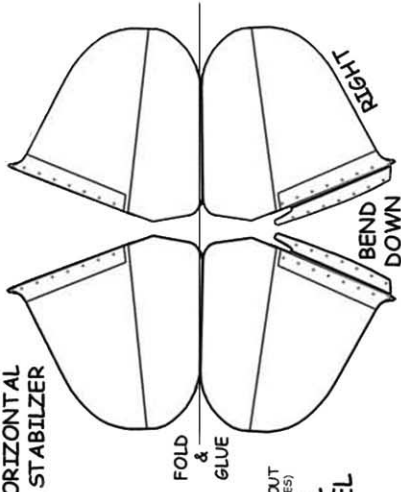

FOLD
&
GLUE



SCORE ALL
FOLD LINES
SMILE !

GLUE ENGINE HERE

WRAP AROUND
UPPER GEAR

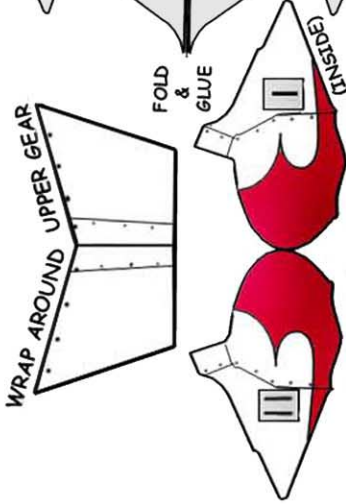

FOLD
&
GLUE

GO FIND A
COUPLE
BUTTONS
ABOUT THIS
SIZE

GLUE
BUTTON
HERE

LANDING GEAR

(DON'T EVEN CONSIDER
TACKLING THIS WITHOUT
LOOKING AT THE INSTRUCTIONS)



GLUE TO
CENTER
OF UPPER
WING

GLUE
BUTTON
HERE



WHEELS

GLUE TO OUTSIDE
OF BUTTONS

LG
DETAIL



WING FILLET
(EITHER SIDE)

CURVE
BEFORE
GLUING

GLUE WING CENTER SECTION HERE

(CURVE TOP
OF WING
TO CREATE
AIRFOIL)
AND
DO
DIHEDRAL

GLUE WING CENTER SECTION HERE

NR2100

NR2100

ASSEMBLY
AND HISTORY
INFO IS WAITING @

WWW.FIDDLERSGREEN.NET

FYN/99

OTHER RACERS AVAILABLE!

GEE BEE R-1

THE FLYING SILO

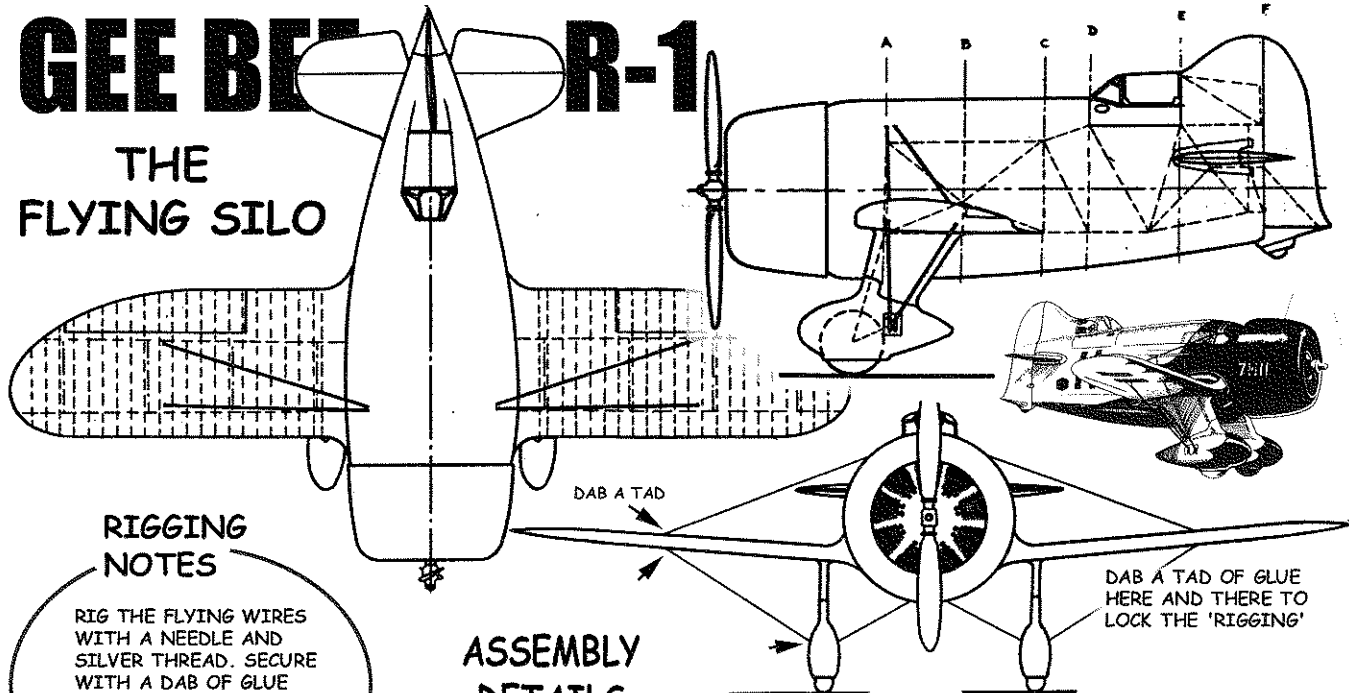

RIGGING NOTES

RIG THE FLYING WIRES WITH A NEEDLE AND SILVER THREAD. SECURE WITH A DAB OF GLUE

ASSEMBLY DETAILS

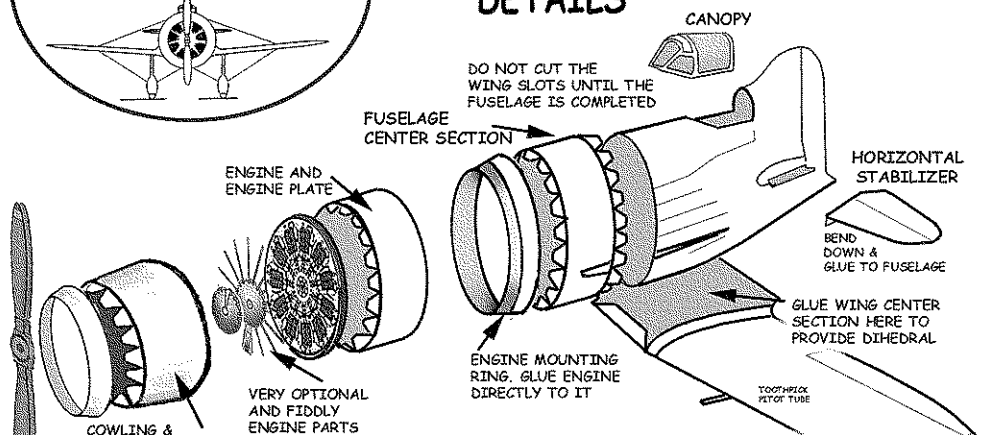

Specifications:

| | |
|------------|-------------|
| Wing Span | 25 feet |
| Length | 17' 9" |
| Dihedral | 4.5 degrees |
| Engine | PW Wasp jr |
| HP | 550 |
| Wt (empty) | 1840 lb |
| Wt (full) | 3075 |
| Fuel Cap | 160 gal |
| Oil Cap | 18 gal |

BACKGROUND: Perhaps the best-known of all "Golden Age" American racing aircraft, the Gee Bees were produced by the five Granville Brothers and their associates. The "Gee Bee" name was derived from the initials of the manufacturers.

Beginning in 1929 with biplanes, the Granvilles soon turned to construction of low-wing sport aircraft, with a sideline excursion into a canard experimental machine. Competition types were the next step, and as the result of early successes, work began during 1932 on the R-1 and R-2 racers, which were structurally quite similar. The R-1 was powered by a Pratt & Whitney Wasp Sr. engine, rated at about 800 horsepower. The R-2, designed for use in cross-country events, featured a Wasp Jr. engine of approximately 550 horsepower, which enabled a less bulky cowling to be fitted.

The wings of both aircraft utilized an M-6 airfoil, and were covered with plywood, which in turn was covered with fabric. Fourteen coats of lacquer, expertly applied by painter George Agnoli, created the high-gloss finish.

The R-1 was first flown during August of 1932, by Russell Boardman. After the initial flight, modifications to the fin and rudder were performed to improve directional stability.

Although Boardman was scheduled to pilot the R-1 in the National Air Races, he was injured in another aircraft, and temporarily put out of action. Thus, Jimmy Doolittle took over, and proceeded to capture the world's speed record, with an average of 252.686 miles per hour. Soon afterward, he won the Thompson Trophy Race over a closed course.

Lee Gehlbach, piloting the R-2 sister ship, placed fourth in the Bendix cross-country race, fifth in the Thompson Trophy event, and third in a competition limited to aircraft with engines of 1,000 cubic inches or less displacement.

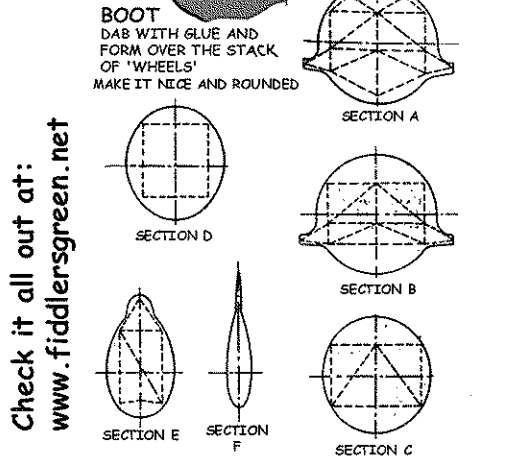
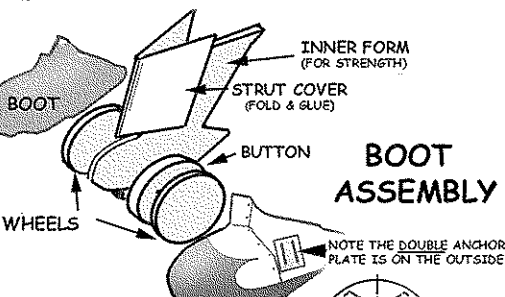

Check it all out at: www.fiddlersgreen.net

DON'T GET RIPPED OFF !!

IF you have been charged for any Fiddlers Green™ model CD ROM(s) and have NOT been offered the Magic Electronic Key feature© which entitles you to free new Fiddlers Green models for the ENTIRE year following your purchase.. the electronic files probably have been pirated and you and I have most probably been ripped off!

Fiddlers Green CD ROMs of Fiddlers Green model files must be registered DIRECTLY with Fiddlers Green. If you have purchased this electronic file or CD rom from a reseller who is unable to offer you directly, the free follow up models, please email me immediately with as much information as possible regarding how and where you bought the pirated product. There is a reward waiting.

Contents

- * FIDDLERS GREEN Copyright & Fair Use
- * Warranty And Disclaimer
- * Contact Me

Copyright And Fair Use

All images and software are copyrighted. Permission is granted ONLY for non-commercial personal use. They may not be duplicate in any form, including electronic, mechanical or printed, for sale. All rights are reserved and duplication by any means, including, but not limited to, methods of printing, electronic storage and disk copies, is prohibited without permission. Payment of the fee for the digital Fiddlers Green product entitles you to use the program on a single computer; it does not transfer ANY title or ownership. If you wish to use artwork, an instructional sheet or model file for other than for your own personal use, ie: for a club contest or school program, PLEASE contact me for written permission first. NOTE: You , as the registered owner, are permitted to take this disk to any copy service (kinkos, etc) and get printouts of model files for your own use.

Only the digital SAMPLE MODELS and/or electronic instructions may be freely distributed, provided this file and the copyright notice remains intact. You may NOT duplicate, sell or give away, in any form, any copy of the CD ROM version. Only the copyright owner, CHIP FYN/FIDDLERS GREEN can give permission for copies to be made. These free sample Files MUST NOT BE SUBJECT TO A SURCHARGE.

Web masters and site owners please contact me (chipfyn@uswest.net) for permission prior to making or distributing any copy(s) of model files or instruction sheets. You are expected to honor this Personal-Use Copyright Notice.

THE PROGRAMS AND INFORMATION ARE PROVIDED "AS IS". NO OTHER WARRANTIES OF ANY KIND, EXPRESS OR IMPLIED, ARE MADE AS TO IT OR ANY MEDIUM IT MAY BE ON. FIDDLERS GREEN and/or Chip Fyn DISCLAIM ALL OTHER WARRANTIES, EITHER EXPRESSED OR IMPLIED, INCLUDING BUT NOT LIMITED TO IMPLIED WARRANTIES OF MERCHANTABILITY AND FITNESS FOR A PARTICULAR PURPOSE OR NON-INFRINGEMENT, WITH RESPECT TO THE SOFTWARE AND THE ACCOMPANYING WRITTEN OR GRAPHIC MATERIALS. FIDDLERS GREEN and/or Chip Fyn ASSUMES NO RESPONSIBILITY FOR ERRORS OR OMISSIONS IN THIS PUBLICATION OR OTHER DOCUMENTS WHICH ARE REFERENCED BY OR LINKED TO THIS PUBLICATION.

<http://www.fiddlersgreen.net>
chipfyn@uswest.net

FIDDLERS GREEN LEGAL DEPT
1650 S. Arizona Ave. #160
Chandler, AZ, 85248 USA

Copyright © 1998-1999 Fiddlers Green. All rights reserved.